



Exhaust Systems Engine Mounts Carb Air Boxes

Shrouds • Seats • Piston • Turbine • Radial • Vintage • And More...



BELLANCA 17-31A VIKING WITH LYCOMING IO 540 ENG

Item	Part Number	Description
1	191744-10	MUFFLER LEFT HAND
2	191768-10	MUFFLER RIGHT HAND
3	191930-0	TAILPIPE LEFT HAND
4	191931-0	TAILPIPE RIGHT HAND
5	099004-254	CLAMP TAILPIPE
6	191959-0	SHROUD LEFT HAND
7	191842-0	SHROUD RIGHT HAND
-	77611	GASKET
-	191956-20	AIR INDUCTION ASSY
-	191524	ENGINE MOUNT
-	J-9868-5	SHOCK MOUNT

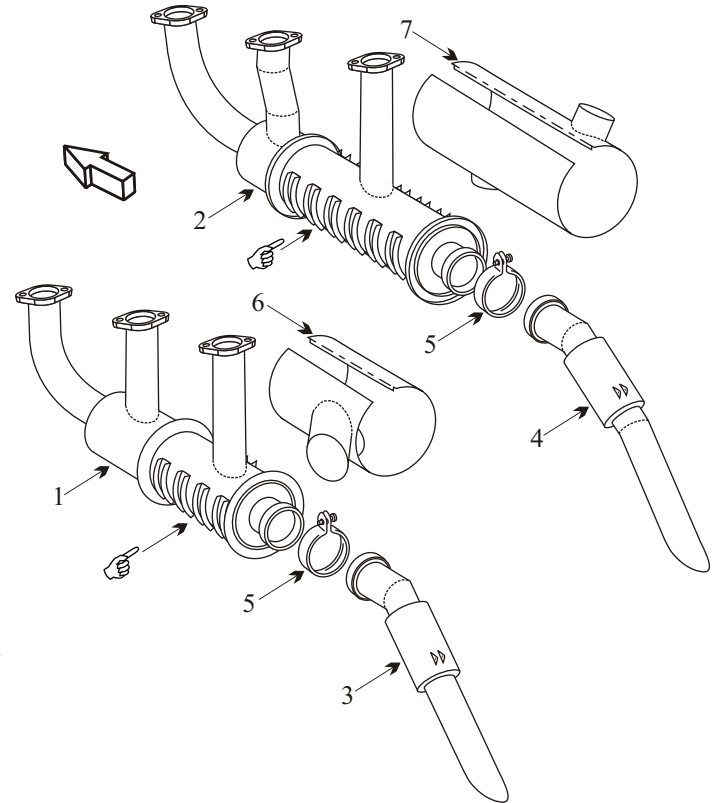

AD 76-23-03 R1

Applies to S/N's 31-15 and on.

Inspect exhaust system for cracks and for freedom of movement in ball joints.

Inspection required every 100 hrs of operation.

- Inspect the area where riser attaches to the body of the muffler for cracks.

- This muffler does not require flame tubes or cones.

☞ A pressure test inspection is advisable for this muffler.

(toll free) 1-888-388-8803 1-780-447-5955 Fax: 1-780-447-5980
 sales@acornwelding.com parts@acornwelding.com www.acornwelding.com