



# Exhaust Systems Engine Mounts Carb Air Boxes

Shrouds • Seats • Piston • Turbine • Radial • Vintage • And More...



## CESSNA 400 CORVALIS TT WITH CONTINENTAL TS10-550-C ENGINE

Item	Part Number	Description
1	657005	ELBOW ASSY RIGHT HAND
2	657007	RISER RIGHT HAND CENTER
3	657010	HEADER RIGHT HAND TEE ASSEMBLY
4	657006	ELBOW ASSY LEFT HAND
5	657008	RISER TEE LEFT HAND CENTER
6	657009	HEADER LEFT HAND TEE ASSEMBLY
7	657011	RISER ADAPTER
8	654331	CROSSOVER BYPASS ASSEMBLY
9	654321	HEADER BYPASS LEFT HAND
10	654329	TAILPIPE LEFT HAND
11	654411	HEATER
12	653337	CLAMP TAILPIPE TO TURBO
-	628260	GASKET
-	652456	GASKET WASTEGATE
-	636465	GASKET TURBO CHARGER
13	654333	TIE ROD
-	LA71203000	ENGINE MOUNT

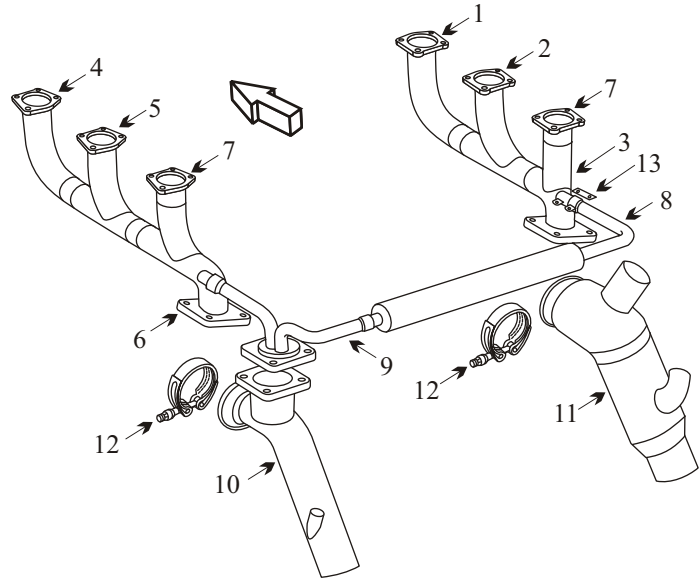

- Inspect transition for blisters or cracks starting at the bypass.
- Inspect joints for freedom of movement and distortion.
- Some of the parts for this aircraft are Inconel. Although Inconel is a far superior metal, it is more difficult to inspect. Inconel tends to corrode from the inside without showing signs of flaking or bulging like stainless steel. The carbon on the inside of the muffler should be removed to properly inspect the component. If the welds are developing pinholes the component will not pass an internal inspection.
- Slip fit stacks should be ordered as a complete assembly to ensure good joint integrity with smooth slip fits.

### TCM SB10-1

Ensure Transition Tie rod and bushing are able to move. Check transition for cracking at flange and in body. 25 hour inspection: Initial inspection on systems with prior maintenance history. Inspect Transition assembly after installing new transition.

50 hour visual inspection: Components, joints and attachment points. Reference TCM SB for more details.

(toll free) 1-888-388-8803 1-780-447-5955 Fax: 1-780-447-5980  
 sales@acornwelding.com parts@acornwelding.com www.acornwelding.com