



# Exhaust Systems Engine Mounts Carb Air Boxes

Shrouds • Seats • Piston • Turbine • Radial • Vintage • And More...



## CESSNA T-206H STATIONAIR WITH LYCOMING TIO-540-AJ1A ENGINE

Item	Part Number	Description
1	40G22384	ADAPTER EXHAUST PIPE CYL #1
2	40B22190	PIPE EXHAUST CYL #1
3	40B22621	PIPE EXHAUST CYL #3
4	40B22193	PIPE EXHAUST CYL #5
5	40B22267	PIPE EXHAUST INTER CYL #5
6	40C22381	FLANGE EXHAUST MANIFOLD
7	40D22382	COUPLING V-BAND EXHAUST TO TRANSITION
8	78246	GASKETS V-BAND COUPLING 2 1/4" TUBE
9	40B22380	PIPE EXHAUST LEFT CYL #6
10	40G22384	ADAPTER EXHAUST PIPE CYL #4
11	40B22379	PIPE EXHAUST LEFT CYL #4
12	40B22318	PIPE EXHAUST CYL #2
13	47C22625	TRANSITION ASSY
14	1254022-1	SHROUD
15	1250992-1	TAILPIPE
16	1250999-1	TAILPIPE EXTENSION (Need Kit NK206-53-01)
17	S1921-1	CLAMP TAILPIPE
18	S3262-6	CLAMP TURBO BY PASS TAILPIPE
19	1250992-8	
20	1250992-6	
21	1250992-7	
-	75845	GASKET TRANSITION-WASTEGATE
-	24096-225-N	GASKET V-BAND COUPLING <small>TRANSITION TO WASTEGATE</small>
-	40D22383	COUPLING V-BAND
-	LW-18234	GASKET
-	0514213-1	SEAT BASE FRAME

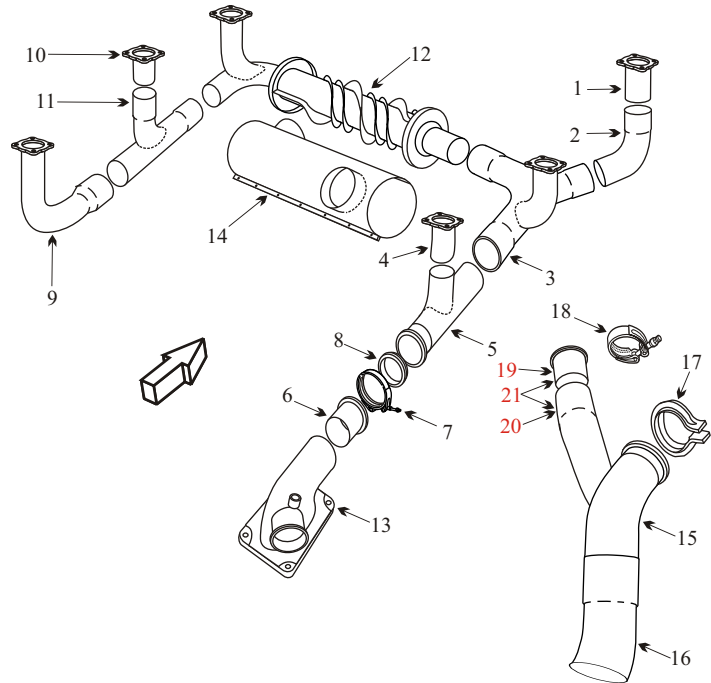

- Some of the parts for this aircraft are Inconel. Although Inconel is a far superior metal, it is more difficult to inspect. Inconel tends to corrode from the inside without showing signs of flaking or bulging like stainless steel. The carbon on the inside of the exhaust parts should be removed to properly inspect the components. If the welds are developing pinholes the component may not pass an internal inspection.

(toll free) 1-888-388-8803 1-780-447-5955 Fax: 1-780-447-5980  
 sales@acornwelding.com parts@acornwelding.com www.acornwelding.com