

CESSNA 411

Item	Part Number	Description
1	8108-201	STACK ASSY RIGHT HAND INBOARD
2	996-4	STACK ASSY RIGHT HAND OUTBOARD
3	9910379-36	ELBOW RIGHT ENGINE
4	996-46/66	CROSSOVER RIGHT ENGINE
5	9910314-8	SLIP JOINT RIGHT ENGINE
6	996-54	TURBO INLET RIGHT ENGINE
7	996-55	TURBO BYPASS RIGHT ENGINE
8	996-58	TAILPIPE RIGHT ENGINE
9	8109-202	STACK ASSY LEFT HAND INBOARD
10	995-3	STACK ASSY LEFT HAND OUTBOARD
11	9910379-37	ELBOW LEFT ENGINE
12	9910379-35	CROSSOVER LEFT ENGINE
13	994-61	TURBO INLET LEFT ENGINE
14	995-62	TURBO BYPASS LEFT ENGINE
15	995-58	TAILPIPE LEFT ENGINE
16	006-250	SPRING KIT 5 KITS PER ENGINE
-	628260	GASKET
-	VARIOUS	INDUCTION CANISTER
-	VARIOUS	SEAT BASE

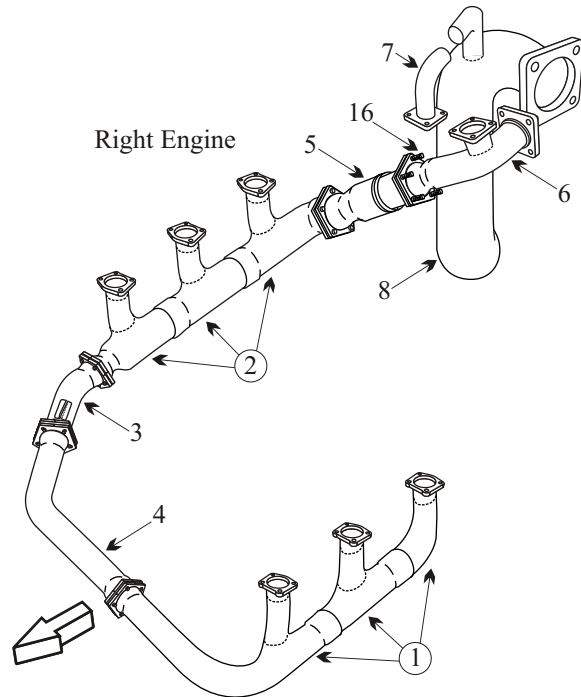

AD 2000-01-16

Applies to all S/N's

Visual inspection of exhaust system every 50 hrs or 30 days of operation.

Remove/inspect tailpipes for cracks, corrosion, holes or distortion every 12 months.

Inspect/pressure test exhaust system every 12 months.

Replace multi-segment V-band clamps every 500 hrs of operation.

Remove exhaust system from slip-joints aft to all turbo-charger components every 2500 hrs of operation or 12 yrs whichever occurs first and send to approved repair facility.

- Inspect tailpipes for internal pitting and wall thickness especially at the outside radius, which is the thin section, and at support bracket.
- Inspect joints for freedom of movement and distortion.
- Slip fit stacks should be ordered as a complete assembly to ensure good joint integrity with smooth slip fits.

