

PIPER PA-31-350 CHIEFTAIN

Item	Part Number	Description
1	LW-10159	RISER RIGHT HAND FRONT
2	LW-10160	RISER RIGHT HAND CENTER
3	LW-10161	RISER RIGHT HAND REAR
4	LW-15849	TUBE INTERMEDIATE RIGHT FRONT
5	LW-16621	ELBOW INTERMEDIATE RIGHT CENTER
6	LW-16620	ELBOW INTERMEDIATE RIGHT REAR
7	LW-10164	RISER LEFT HAND FRONT
8	LW-10163	RISER LEFT HAND CENTER
9	LW-10162	RISER LEFT HAND REAR
10	LW-15849	TUBE INTERMEDIATE LEFT FRONT
11	LW-16696	ELBOW INTERMEDIATE LEFT CENTER
12	LW-16697	ELBOW INTERMEDIATE LEFT REAR
13	LW-12437	TRANSITION
14	40310-10	UPPER TAILPIPE
15	40310-09	LOWER TAILPIPE
16	6100	HEATER PIPE
17	LW-12093-5	CLAMP ELBOW TO TRANSITION
18	LW-12093-6	CLAMP BYPASS TO VALVE BOTTOM
19	LW-12125-3	CLAMP BYPASS TO TRANSITION TOP
20	587-584	CLAMP TAILPIPE
21	78083	GASKET ELBOW TO TRANSITION
22	24096-225N	GASKET WASTEGATE
NS	LW-15619	GASKET MANIFOLD (STANDARD)
NS	LW-15486	GASKET MANIFOLD (NO BLOW)
23	54916-02	INDUCTION AIR TUBE ASSY
24	LW-18248	ROD TURBO SUPPORT RIGHT HAND
NS	LW-16965	ROD TURBO SUPPORT LH (2 PC)
25	LW-18020	ROD TURBO SUPPORT LH (1 PC)
26	LW-18459	BRACKET SUPPORT ROD
27	LW-12435	BRACKET SUPPORT ROD
28	LW-18302	TURBO MOUNT
29	LW-12452	TURBO MOUNT
NS	J-9612-8	SHOCK MOUNT
NS	J-7763-1	SHOCK MOUNT
NS	VARIOUS	SEAT BASE

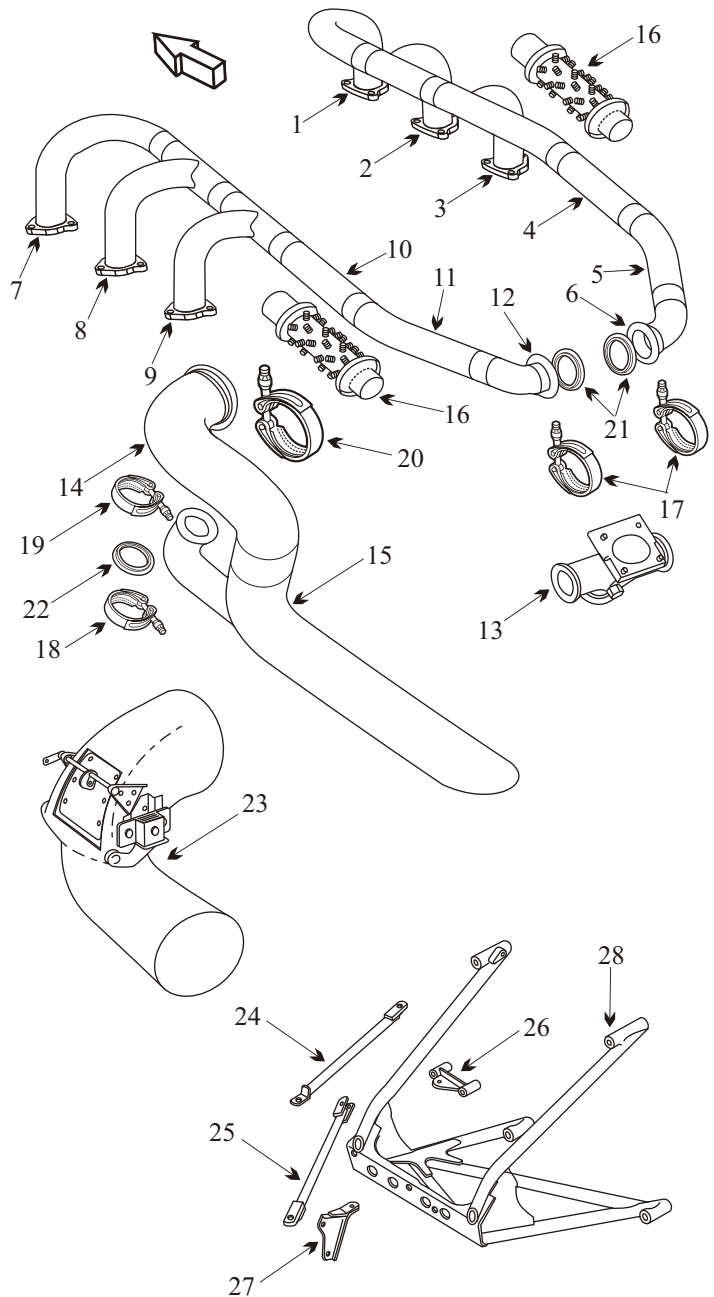

- Inspect two piece tailpipes to ensure that they can be disassembled and the ends are standard nominal dimension. This will determine if the new ordered stack will fit into the old stack.
- Inspect joints for freedom of movement and distortion.
- Inspect tailpipes for internal pitting and wall thickness especially at the outside radius, which is the thin section, and at support bracket.
- Inspect transition header for cracks
- Inspect the internal valve shaft for excessive wear, ensure that the waste gate valve opens and closes properly and the spring has enough tension to return the valve.
- Slip fit stacks should be ordered as a complete assembly to ensure good joint integrity with smooth slip fits.

AD 82-16-05

Applies to S/N's 31-2 thru 31-8312019 equipped with P/N's 455-301, 555-376, 555-511 or 555-366 couplings. Remove exhaust couplings and tailpipe and inspect V-band segments for cracks.

Inspect flanges for cracks or distortion.

Inspection required every 100 hrs of operation.