

# PIPER PA-32RT-300T LANCE II

# PIPER PA-301T SARATOGA

# PIPER PA-32R-301T TURBO SP

WITH LYCOMING TIO540 S1AD ENGINE

Item	Part Number	Description	Code
1	LW-10159	RISER RIGHT FRONT CYL #1	
2	LW-10160	RISER RIGHT CENTER CYL #3	
3	LW-15805	RISER RIGHT REAR CYL #5	
4	78189	ELBOW ADAPTER RIGHT HAND	
5	LW15806	ELBOW RIGHT HAND	
6	LW-10164	RISER LEFT FRONT CYL #2	
7	LW-10163	RISER LEFT CENTER CYL #4	
8	40B21375	RISER LEFT REAR CYL #6	
9	LW-16103	CROSSOVER LEFT HAND	
10	LW-16102	CROSSOVER RIGHT HAND	
11	LW-16858	TRANSITION W/O SPRING OR ROD END	
12	764-501	TAILPIPE ELBOW	
13	98705-00	TAILPIPE	
14	762-447	TAILPIPE SHROUD	
15	LW-15437	CABLE ASSY EXHAUST RETAINER	
16	LW-14525	CLAMP	
17	MVT69861-377	COUPLING TAILPIPE ATTACHED	
NS	17189-200N	GASKET	
18	LW-15765	ROD END TRANSITION	
NS	LW-15486	GASKET	
19	LW-12093-5	CLAMP WASTEGATE	
20	LW-16090	BRACKET TURBO MOUNT	
NS	98551-02	INDUCTION AIR BOX (300T ONLY)	
NS	38613-02	INDUCTION AIR BOX	
21	LW-15979	MOUNTING BRACKETS STRUT TURBO	
NS	LW-16953	MOUNTING BRACKETS STRUT TURBO	A
22	LW-15978	MOUNTING BRACKETS STRUT TURBO	
NS	LW-16952	MOUNTING BRACKETS STRUT TURBO	A
23	LW-15764	SUPPORT BRACKET TURBO CHARGER #3 CYL	
24	LW-14454	STRUT TURBO CHARGER FRONT	
NS	38020-00	ENGINE MOUNT	300-T ONLY
NS	38729-18	ENGINE MOUNT	SN <sup>8129001</sup> and on
NS	J-9613-55/19	SHOCK MOUNT 2 EACH	
NS	VARIOUS	SEAT BASE	

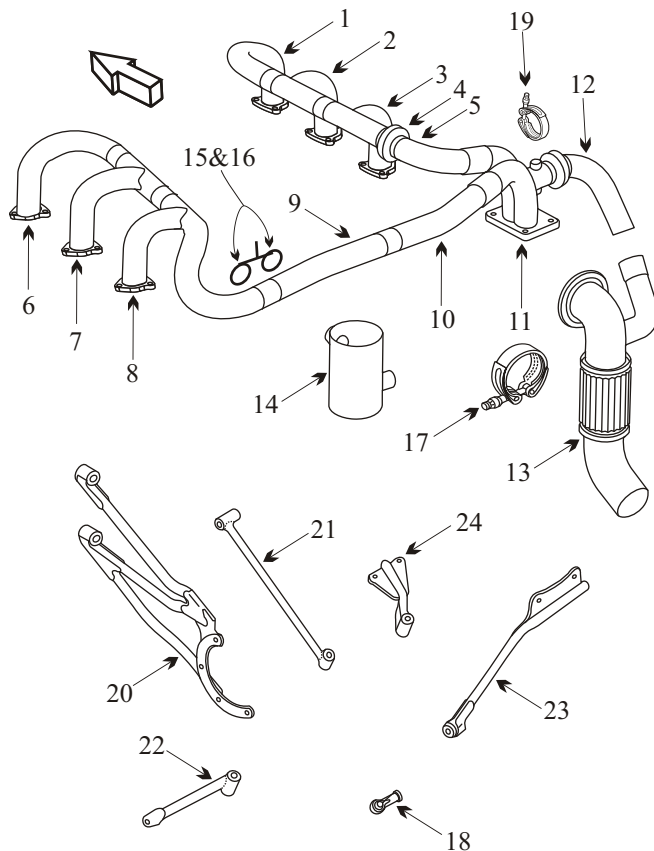

### Usable on Codes

A: Used with 20° angle engine mount with 2" dia hole

#### AD 80-20-05

#### Piper PA32RT-300T

See AD for applicable S/N's.

Inspect tailpipe, tailpipe flange and coupling for cracks.

#### Piper PA32R-301T

Applies to S/N's 32R-8029001 thru 32R-8629006 and 3229001 thru 3229003.

Inspect engine mount for cracks.

Inspection required every 100 hrs until compliance with Part 2 of Piper SB 955 accomplished.

- Inspect joints for freedom of movement and distortion.
- Inspect the internal valve shaft for excessive wear, ensure that the waste gate valve opens and closes properly and the spring has enough tension to return the valve.
- Slip fit stacks should be ordered as a complete assembly to ensure good joint integrity with smooth slip fits.