



Exhaust Systems Engine Mounts Carb Air Boxes

Shrouds • Seats • Piston • Turbine • Radial • Vintage • And More...



PIPER J3 & PA-1 1 WITH CONTINENTAL 65 HP

Item	Part Number	Description
1	71053-002	MUFFLER
2	71802-000	STACK LEFT HAND
3	70671-000	STACK RIGHT HAND
4	74501-000	TAILPIPE
5	70912-000	TAILPIPE SHROUD
6	70963-000	MUFFLER SHROUD
7	70591-002	CLAMP MUFFLER
8	71261-000	SLIDE CLIP MUFFLER
-	80002-022	CLAMP TAILPIPE BRACE
-	72691-000	CLAMP TAILPIPE
-	70723-000	FUEL TANK
-	71163-000	ENGINE MOUNT
-	627429	GASKET

AD 68-05-01

Inspect exhaust system for cracks, corrosion, heat damage or weld separations.
 Less than 950 hrs of operation inspect every 100 hrs.
 More than 950 hrs of operation inspect every 50 hrs.
 Repair or replace if defects found.

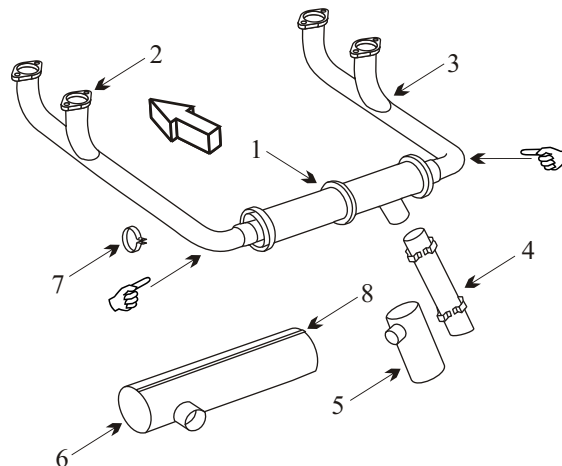

- The muffler must have inner flame tubes still attached to be serviceable.
- Inspect wear areas on the aluminum shroud at shroud ring areas.
- Inspect the Y-joint at the aft cylinder stack for cracks.
- ☞ This part has a hot area at the elbow. Inspect this area for black flaking metal and bulges.

(toll free) 1-888-388-8803 1-780-447-5955 Fax: 1-780-447-5980
 sales@acornwelding.com parts@acornwelding.com www.acornwelding.com