

## PIPER PA-32-300 CHEROKEE SIX

SN 32-7640001-7940282

## PIPER PA-32R-300 LANCE

SN 32R-7680001-7880068

## PIPER PA-32RT-300 LANCE II

SN 32R-7885001-7985125

## PIPER PA-32R-301 SARATOGA

SN 32-8006001-8506000 AND 8506001 AND UP

## PIPER PA-32R-301 SARATOGA SP

SN 32R-8013001-8613005 AND 3213003-3213041

WITH LYCOMING IO-540 ENGINE

Item	Part Number	Description	Code
1	67517-000	MUFFLER	
2	38159-002	SHROUD TOP	
3	38162-006	SHROUD BOTTOM	
4	38137-005	STACK RIGHT FRONT	
5	38137-006	STACK RIGHT CENTER	
6	38137-007	STACK RIGHT REAR	
7	38137-004	STACK LEFT FRONT	
8	38137-003	STACK LEFT CENTER	
9	38137-002	STACK LEFT REAR	
10	63243-002	CLAMP MUFFLER	
-	77611	GASKET	
-	38080-000	INDUCTION AIR BOX	C
-	69768-000	STEERING HORN	B
-	68710-000	ENGINE MOUNT	A
-	38020-033	ENGINE MOUNT	D
-	38020-000	ENGINE MOUNT	E
-	38729-018	ENGINE MOUNT SN <sup>32R 8113001</sup> and on	
-	38727-002	ENGINE MOUNT <sup>301</sup> SN <sup>32R 8106001</sup> only and on	
-	J-3804-31	SHOCK MOUNT	D
-	J-3804-27	SHOCK MOUNT	A
-	J-9613-19/-12	SHOCK MOUNT 2 EACH SARATOGA	

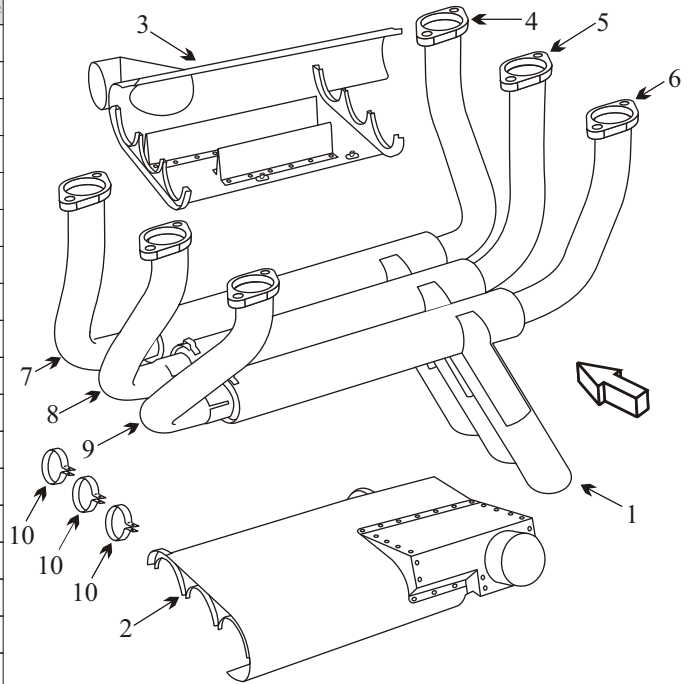

### Usable on Code

- A: PA-32-300 SN 32-40000 and on,  
PA-32-301 SN 32-8006001 to 8006116
- B: PA-32-300 SN 32-7640001 and on
- C: PA-32-300 SN 32-7640001 and on,  
PA-32R-301 SN 32R-321-3103
- D: PA-32R-300 SN-7680001 to 7780095
- E: PA-32R-300 SN 32R-7780096 and on,  
PA-32R-301 SN 32R-8013001 to 8013150  
PA-32RT-300 SN 32R 7885001 to 7885302  
PA-32R-301 SN 32R 8013001 to 8013150

- Riser slip joints into muffler should move freely to avoid stress on muffler end plates and to allow for service and inspection. The riser stack ends tend to flare out and seize inside muffler preventing removal of the risers. It would be wise to check if the stacks can be removed before ordering just the muffler.

#### AD 93-05-10

#### Piper PA-32R-300

Applies to S/N's 32R-7680001 thru 32R-7880068, 32R-7885001 Thru 32R-7985105 and 32R-7887001 thru 32R-7987126.

#### Piper PA-32RT-300

Applies to S/N's 32R-7885001 thru -85285.

#### Piper PA-32R-301

Applies to S/N's 32R-8013001 thru 32R-8613005, 3213001 thru 3213037.

Inspect engine mount for cracks.

Inspection required every 100 hrs until compliance with Part 2 of Piper SB 955 is accomplished.

- Inspect muffler for wear areas where the shroud rests on the muffler.