

PIPER PA-46-350P MIRAGE PIPER PA-46-350T MATRIX WITH LYCOMING TIO-540-AE2A ENGINE

Item	Part Number	Description
1	40B19844	RISER RIGHT HAND FRONT CYL #1
2	40B19827	RISER RIGHT HAND CENTER CYL #3
3	47C19845	TRANSITION RIGHT HAND
4	40B19841	RISER LEFT HAND FRONT CYL #2
5	40B19842	RISER LEFT HAND CENTER CYL #4
6	47C19847	TRANSITION LEFT HAND
7	40B19840	ADAPTER CYL #1, #2, #5, #6.
8	40B19975	CROSSOVER RIGHT
9	40B19974	CROSSOVER CENTER
10	40B19850	CROSSOVER LEFT
11	40B19851	TRANSITION ADAPTER
12	47C19848	EXHAUST TRANSITION LEFT HAND
13	40B21011	TAILPIPE LEFT HAND
14	40B22295	HEATER MUFFLER TAILPIPE RIGHT HAND
15	LW-12093-5	V-BAND SEGMENT TO HEADER
16	78084	GASKET
17	LW-12093-6	V-BAND CLAMP TO BYPASS
18	06B19913	GASKET BYPASS TO RH HEADER
19	LW-12093-3	V-BAND CLAMP BYPASS TO RH HEADER
20	75845	GASKET BOTH SIDES OF WASTEGATE
21	40D23255-340M	V-BAND 2 3/4" TUBE (RIVETED) <small>AD 2010-13-07 Compliant</small>
22	07C21135	CLAMP TAILPIPE 2 3/4"
23	07F19872	STRUT TURBO LEFT HAND
24	07F19871	STRUT TURBO RIGHT HAND
25	07A19870	BRACKET TURBO MOUNT LEFT
26	07A19846	BRACKET TURBO MOUNT RIGHT
27	40522416	HEAT SHIELD FRONT
28	40J21019	HEAT SHIELD REAR
29	40J19953	HEAT SHIELD RIGHT SIDE
-	07A21137	BRACKET RIGHT TAILPIPE
-	07A21136	BRACKET RIGHT TAILPIPE
-	07F21138	LINK RIGHT TAILPIPE SUPPORT
-	07A19981	BRACKET CROSSOVER PIPE SUPPORT
-	40G19982	CLAMP 1 1/2" ID X 5/8" WIDE
-	40G19901	LINK LEFT TAILPIPE SUPPORT
-	77611	GASKET
-	89721-034	INDUCTION AIR BOX
30	89137-002	ENGINE MOUNT RDC ENHANCED
30	89137-041	ENGINE MOUNT
31	84198-002	HEAT SHIELD ASSY
32	78077	SLIP FLANGE
33	07C21135	CLAMP
-	J-9613-55	SHOCK MOUNT
-	VARIOUS	SEAT BASE

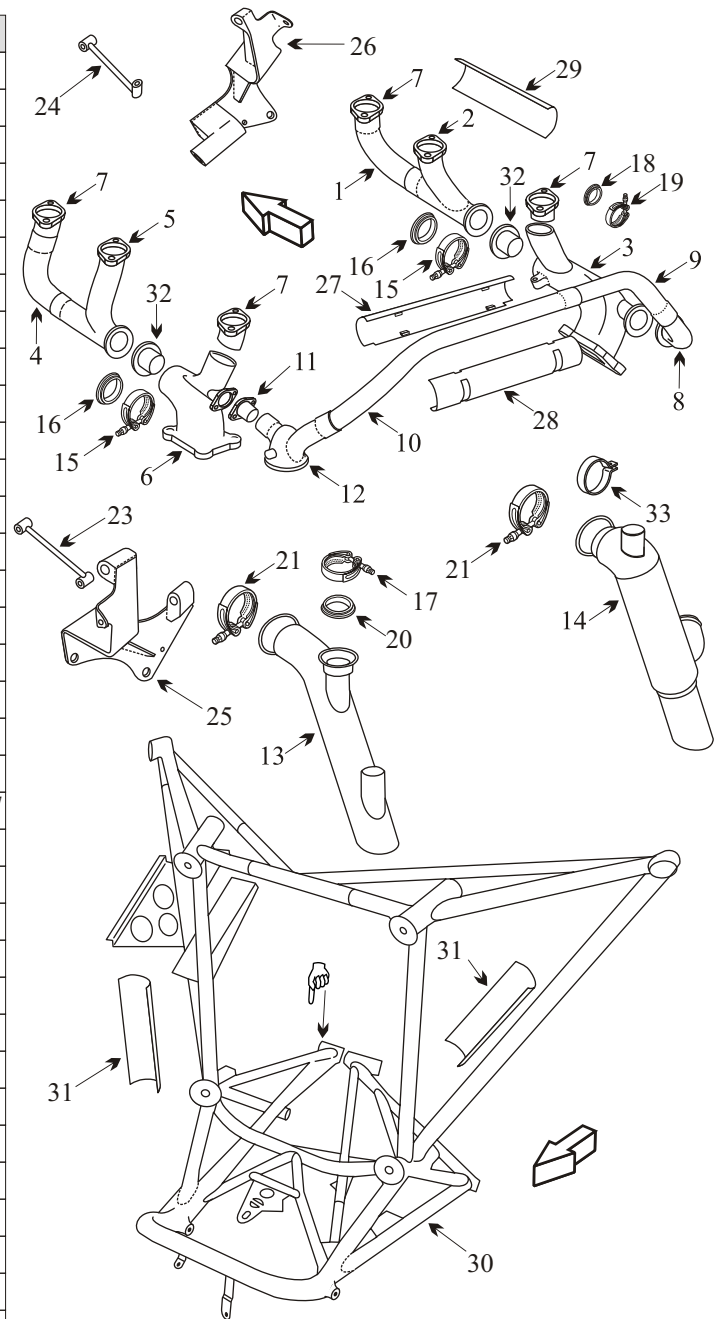

SB #1103

Applies to S/N's 4622003 thru 4622200, S/N's 4636001 thru 4636317.
Inspect engine mount actuator attach feet area for cracks and replace mount if cracks found.
Inspection required every 100 hrs of operation till mount replaced.
Acorn Welding alternate means of compliance RDC #C-RA04-243/D will also relieve repetitive inspections.

- Inspect transition header for cracks.
 - Inspect joints for freedom of movement and distortion.
 - Slip fit stacks should be ordered as a complete assembly to ensure good joint integrity with smooth slip fits.
- ☞ Acorn Welding alternate means of compliance RDC #C-RA04-243/D will also relieve repetitive inspections.

AD 2010-13-07

Replace all spot welded clamps (40D21162-340M and LW-12093-8) with riveted type (40D23255-340M). Ensure all slip joints have movement and flanges line up correctly.